

Design Optimization of Tracking Area List for Reducing Total Signaling Overhead in LTE Systems

Lamia Osman Widaa, Sami Mohamed Sharif

Abstract—In Long Term Evolution systems (LTE) the concept of Tracking Area List (TAL) is introduced. TAL consists of a group of Tracking Areas (TAs), and it is assigned to a User Equipment (UE), the UE does not need to register its location when it moves within TAs of the assigned TAL. If an optimum TAL design is implemented this may result in the reduction of total signaling overhead cost introduced by location update and paging procedures. One of the challenges of mobility management in cellular networks is the reduction of overall signaling overhead while maintaining acceptable performance. In this paper we propose a TAL design optimization for reducing overall signaling overhead algorithm. To achieve optimum TAL design a cell may change its current TAL, and this may cause a service interruption for active UEs in that cell. A budget constrain parameter is introduced to define the maximum number of cells change TALs while maintaining improved performance. For UE mobility modeling the data required can be obtain from the network management system which are cell load and handover statistical data. Markov model is used for UE mobility modeling. We present numerical results, from which we can say that the optimum TAL design returned from the proposed algorithm gave considerable reduction of overall signaling overhead cost compared to the traditional TA design.

Index Terms— LTE, , Location Update, Paging, Signaling Overhead, TAL.

I. INTRODUCTION

In cellular communication networks, mobility management consists of location registration (location update) and paging, and it is one of the most essential techniques to provide communication services to UEs. Mobility management in Long Term Evolution (LTE) is different from that in the third generation mobile telecommunication networks. In LTE, the Mobility Management Entity (MME) is responsible for the mobility management function, and it's connected to a large number of evolved Node Bs (cells) that

are grouped into the Tracking Areas (TAs). The TA is defined as an area in which the user equipment (UE) may move freely without updating the MME. Tracking Area (TA)

is a cluster of evolved Node Bs (eNBs) having the same TA code [9],[10]. In the standard TA scheme, having TA with small size (few number of cells) eliminates the paging signaling overhead; on the other hand having TA with a large size eliminates the location update overhead. When a UE receives a call, the network must page cells within the Location Area (polling) to find that user as quickly as possible. This process all induces system overhead in both system signal and wireless bandwidth consumption. If the wired network knows the exact location of a UE, the paging cost can be reduced to a minimum by polling only the cell in which the UE is situated. On the other extreme case, if the wired network does not have any information about the location of the UE, cells all over the wireless network have to be polled. This costs the maximum system overhead. So the problem is how to find an optimal TA design which gives reduction in signaling overhead and optimal balance between Tracking Area Update (TAU) and paging signaling overhead. Limitations of the tracking Area scheme can be summarized as follows:

- Ping Pong effect: Here if the UE moves back and forth between two or three neighboring TAs and this will cause excessive TAU, because when UE enters a new TA it will perform TAU.
- Massive Mobility Signaling Congestion: Here If a large number of users simultaneously move into a hotspot cell, this will cause excessive TAU from the UEs, in a short period of time.

In LTE networks Tracking Area List (TAL) scheme has been introduced to solve a problems existing in the standard TA scheme such as ping-pong, massive mobility problems discussed above and localized spikes in uplink traffic problem [1],[5]. The MME provides the UE with a list of TAs where the UE registration is valid. The network allocates a list with one or more TAs to the UE. The UE may move freely in all TAs of the list without updating the MME. When the MME pages a UE, a paging message is sent to all cells in the TAL.

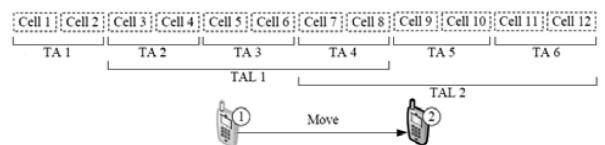

Fig. 1: An example of a TAL scheme

Manuscript received February 6, 2014, revised May 1, 2014.
Lamia O.Widaa is with the Department of Telecommunication Engineering, University of Science & Technology, Khartoum Sudan. (e-mail: lolawidaa@gmail.com).
Sami M.Sharif is with the Department of Electrical & Electronic Engineering, University of Khartoum, Sudan. (e-mail: smsharif@uofk.edu).

Fig.1 above shows an example of a TAL scheme. In Long Term Evolution (LTE), the Mobility Management Entity is connected to a group of evolved Node Bs (eNBs; the LTE term for base stations). The radio coverage of an eNB (or a sector of the eNB) is called a cell (see the dashed squares). Every cell has a unique cell identity. The cells are grouped into the Tracking Areas (TAs; e.g., TA 1 contains Cell 1 and Cell 2). Every TA has a unique TA Identity (TAI). The TAs are further grouped into TA Lists (TALs). In Fig.1 TAL1 consists of TA 2, TA3, and TA4. A UE stores the TAL that includes the TA where the UE resides. In Fig.1, the UE is covered by Cell 5, and the TAL it stores is $TAL1 = \{TA 2, TA 3, TA 4\}$. If the LTE network attempts to connect to the UE, it asks the cells in the TAL (e.g., Cell 3-Cell 8) to page the UE. Every eNB periodically broadcasts its TAI. The UE listens to the broadcast TAI and checks if the received TAI is in its TAL. If so, it means that the UE does not move out of the current location. When the UE moves from Cell 5 to Cell 7, it receives the TA4 identity broadcast from eNB7. Since TA4 is included in TAL1, the UE still resides in the same location. When the UE moves to Cell 9 the received TA5 identity (broadcast from eNB9) but is not found in TAL 1, which means that the UE has moved out of the current location. In this case the UE executes the location update procedure to inform the MME that it has left TAL1. The MME then assigns a new TAL to the UE. Now the new TAL is $TAL2 = \{TA4, TA5, TA6\}$. In LTE systems TALs for different UEs may have different sizes, and the newly assigned TAL may be overlapped with the previously assigned TAL (as shown in the previous example) [6].

If the information of each individual UE's movement and calls were available for the network, then designing an optimum TAL would become trivial and could essentially result to elimination of signaling overhead. In this situation the cell could give a specific, tailored list to each UE including all the cells the UE is intended to pass before it will be called. This information, if available at all, is costly to obtain. Moreover, the validity of the information expires fast, because the trace is the history of the UE's movement, and the UE's intention of where and when to move in future is unknown [4].

Finding an optimum design of TA and TAL (which gives minimum signaling overhead) is a challenging task in LTE network, and in general the goal of the location management is to find balance between the following:

- More frequent update (reduce polling cost).
- Rare location update, storing less information about users, reduces computational overhead (higher polling cost).
- Optimize the design of TAs or TALs, less handoff, quicker locating of user.

In this paper we proposed a TAL design optimization for reducing overall signaling overhead algorithm, this algorithm returns an optimum design of TALs (which gives minimum total signaling overhead) by using the available data obtained from the network management system which are cell load and handover statistical data during a given period of time. The optimum design was obtained by initially chosen random cells and changing the TAL of those cells till we reach the optimum design for all TALs in the network. In general the TAL of a cell can be modified at a time by either deleting or adding one of the cells in the TAL. For every cell in the network and if the

cell changes its TAL this will causes service interruption, the cell load of the cell (number of active and idle UEs in the cell) is used to measure this service interruption in that cell. When applying the design to the suggested network it gave considerable reduction of total signaling overhead.

The rest of this paper is organized as follows: In Section II related works is summarized. Section III describes the proposed algorithm. Numerical results are presented in Section IV. Finally, Section V concludes the paper.

II. RELATED WORK

In Personal Communication Services Networks (PCS) several strategies were proposed to reduce the location update cost. In [7] the researchers studied a special case of a location tracking algorithm called the Alternative Location Algorithm (ALA). This special case is referred to as the Two Location Algorithm (TLA). An analytical model is proposed to compare the performance of TLA and the IS-41 protocol. The study indicates that the performance of TLA is significantly affected by the user moving patterns and the call traffic. If the user mobility is higher than the call frequency or the user tends to move back to the previously visited registration areas, then TLA may significantly outperform IS-41.

Many researches in the literature aimed to contribute in reducing total signaling overhead in LTE networks. TAL concept is expecting to reduce the overall signaling overhead when compared to traditional TA concept. In [2] the authors proposed a method for allocating and assigning TALs for LTE networks. This method is called "Rule of thumb". The optimum conventional TA design was compared with the proposed TAL; it found that TAL works best if a dynamic frequent reconfiguration is applied for different time intervals. The Rule of thumb method is simple and cannot guarantee to give an optimum TAL design because each cell in the network is selfishly optimizing the signaling overhead according to their own data and does not considered the impact of the other cells on their modified TAL.

In [4] the authors introduced an approach for allocating and assigning TALs, here the impact of neighbor cells was considered, and the data required for TAL allocation is the same data used of TA design, which are the cell load and handover statistics. These data can be obtained from the mobility management system in the network. In the proposed scheme different users UEs in one cell are holding different TALs according to the original cell they are registered in. The authors aimed to show that even with a simple algorithm a TAL design is able to reach a lower overall overhead than the conventional TA design. The proposed algorithm takes into account the impact of neighbor cells in the allocation of TALs. The impact of the neighbor of neighbor cells is not considered, if it was considered this will gives more accurate design, but the algorithm will be complicated.

In [1] the local search algorithm is introduced for designing TALs. The input data required for implemented the algorithm was the same data required for designing standard TA (cell

Design Optimization of Tracking Area List for Reducing Total Signaling Overhead in LTE Systems

load and handover statistics). The basic operation of the algorithm was to modify the TAL of a cell at a time by either deleting or adding one of the cells in the TAL, at each trial the overall signaling overhead is calculated, the algorithm was repeated until lower signaling overhead was reached. Here one of the disadvantages is that an optimum TA design was required before starting the algorithm. The algorithm showed lower overall signaling overhead when compared with the standard TA scheme.

All of the algorithms mentioned above were implemented using the available statistical data from the network mobility management system and were independent of UE traces. The design of TALs based on UEs traces is also possible. Here each cell is able to assign different TALs to different UEs. But if the UEs change their movement, which is quite probable the TALs would become inefficient.

III. TAL DESIGN OPTIMIZATION ALGORITHM

From the design of the proposed algorithm we tried to find an optimum TALs design, which gives minimum overall signaling overhead. Here a budget parameter is defined because the TAL of a cell can be modified at a time t by either deleting or adding one of the cells in the TAL. For every cell in the network and if the cell changes its TA (change its e nodeB) this will causes service interruption for active UEs on that cell, the cell load (Number of active and idle UEs in the cell at time t) of a cell is used to measure the service interruption in that cell. In [1] the budget constrains parameter B is defined by the following equation:

$$\sum_{i \in N} u_i d_i(t, t^0) \leq B \tag{1}$$

Where:

- N is the number of cells in the network.
- u_i is the cell load of cell i .
- t^0 is initial TA of cell i and t is the TA returned by the algorithm for cell i
- $d_i(t, t^0)$ is a binary vector, $d_i(t, t^0) = 1$ if and only if t^0 of cell $i \neq t_i$.

To find an optimum design of TAL the service interruption is taken into account and the problem can be defined as finding an optimum design of TAL which gives minimum total signaling overhead and satisfies (1) above. The algorithm is examined for different suggested values of parameter B and for the network which described in Section A below.

A. NETWORK DESCRIPTION

Network description is similar to [3]. The network has hexagonal cellular configuration with 61 cells, every cell has a unique cell identity or index (see fig.2 below), and every TA has a unique TA identity (TAI). When UE moves into cell i it resides in the cell for a random period of time and then moves out in the direction of one of six neighbor cells. In the proposed algorithm TAL overlapping was considered which

means that one TA can be included in more than one TAL. The UE mobility model used is markov model. We assumed that the TA consists only of one cell, and no restriction on number of TAs within a TAL. A UE stores the TAL that includes the TA where the UE resides, when the UE moves out from its current TAL in this case it will executes the location update procedure to inform the MME that it has left current TAL. Then the MME assigns a new TAL to the UE. The newly assigned TAL maybe overlapped with the previously assigned TAL as discussed in section I. We assumed that there is no integration between the suggested LTE system and any Radio Access Technology (RAT).

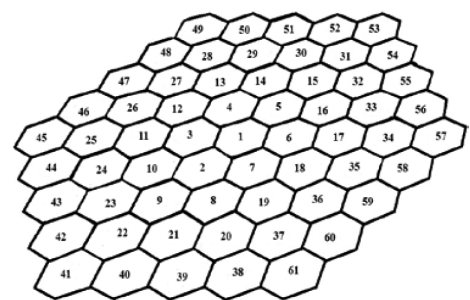

Fig. 2. Network cells

In the proposed network the calculation of the overall signaling is depends on the available statistical data obtained from the network management system. Here the data used for calculation are the cell load and handover statistical data. These data are generated using a UE mobility model. Also the design of TAs and TALs affects the calculation of overall signaling overhead.

B. UE MOBILITY MODEL

UE movement and mobility behavior in a cellular network can be described by cell residence time and handover probability calculated for each cell in the network based on the time series of the visited cells of the UEs [4]. Cell residence time and handover statistics can be obtained from the management system of the cellular network. From the literature there are different UE mobility models that can be used to describe UE mobility behavior [11],[12],[13]. Markov model is widely used for this purpose. And in the proposed algorithm it's used for UE mobility modeling. It's a mathematical model that undergoes transitions from one state to another, between a finite or countable number of possible states. It is a random process usually characterized as memory less and the next state depends only on the current state and not on the sequence of events that preceded it. This specific kind of "memory lessens" is called the Markov property. Markov model have many applications as statistical models of real-world processes.

The Markov model, also known as the random-walk model and it can be applied to cellular systems to describe individual movement behavior of UEs. In this model, the UE at any given time slot will either remain within a cell or move to an

adjacent cell according to a transition probability distribution, this probability is often adjusted to practical observations of UE behavior in cells. In general the markov model can be described by the following:

- A markov chains with finite set S of m states. $S = \{s_1, s_2, \dots, s_m\}$. And in the proposed algorithm we used 7-state markov model ($m = 7$) where each state represents a radio cell in the network. For each cell in the network there are 6 neighbors (or less if the cell is terminal cell such as cell with index 57 in Fig. 2 which has only 3 neighbors).
- The State Transition Probability distribution matrix P with size ($m \times m$). Element p_{ij} in this matrix represents the probability of the movement of the UE from cell i to cell j in next time slot. Fig.3 below shows the state diagram and the transition matrix of 7-state markov model. Cell c represent the current cell of the UE, and cell n_z is one of the neighbor cells of cell c, where $z=1,2,\dots,6$.

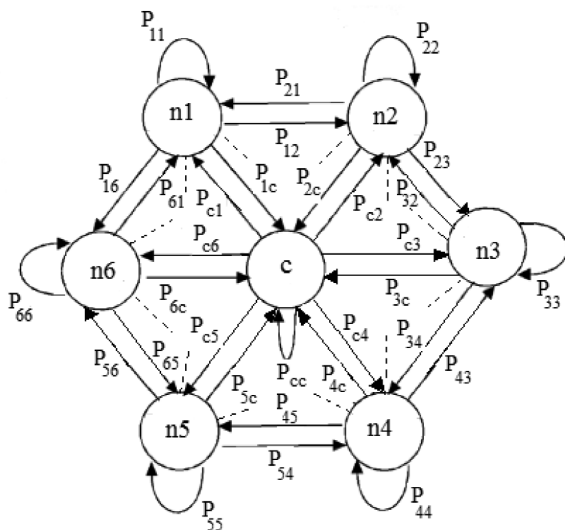

(a) The State Diagram

$P =$

P_{cc}	P_{1c}	P_{2c}	P_{3c}	P_{4c}	P_{5c}	P_{6c}
P_{c1}	P_{11}	P_{21}	P_{31}	P_{41}	P_{51}	P_{61}
P_{c2}	P_{12}	P_{22}	P_{32}	P_{42}	P_{52}	P_{62}
P_{c3}	P_{13}	P_{23}	P_{33}	P_{43}	P_{53}	P_{63}
P_{c4}	P_{14}	P_{24}	P_{34}	P_{44}	P_{54}	P_{64}
P_{c5}	P_{15}	P_{25}	P_{35}	P_{45}	P_{55}	P_{65}
P_{c6}	P_{16}	P_{26}	P_{36}	P_{46}	P_{56}	P_{66}

(b) The Transition Probability Matrix

Fig.3. The state diagram and the transition probability matrix of a 7-state markov model

Probabilities introduced in the transition probability matrix shown in Fig.3 above are defined as the handover probabilities, and can be calculated from UEs handover statistical data obtained from the network management system [3]. The UE can be located in 7 different states during each time slot depending on handover probability of each neighbor cell.

- The steady state probability distribution vector in which π_i is the probability of a UE being in state i (from which cell residence time can be calculated). We assumed that cell residence times are Independent Identical Distributed random variables (IID) with average residence time $1/\lambda$. The steady state distribution of the cell residence time satisfies the following equation:

$$\pi_j = \sum_{i=1}^7 \pi_i P_{ij} \quad (2)$$

And

$$\sum_{j=1}^7 \pi_j = 1 \quad (3)$$

C. UE TRACE MATRIX

In the proposed algorithm the UE trace matrix ($V \times T$) is implemented similar to [1], in which V UEs are traced. Fig.4 below shows one row in the trace matrix, the time interval in which UEs are traced is T and this interval was divided into n time slots (t), the serving cell of UE, at time slot t_i is stored at element (v, t_i) in the matrix, $i=1,2,3,\dots,n$.

The starting cell (C_s) for each UE in the trace matrix can be obtained from (4) below:

$$P_{cs} = \frac{u_i}{\sum_{j=1}^N u_j} \quad (4)$$

Where:

P_{cs} is the probability that cell i will be the starting cell for user UE_v ,

u_i is the cell load (number of Active and Ideal users in cell i) of cell i.

N is the number of cells in the network.

For the design of the proposed algorithm we assumed the following:

- The initial cell load of each cell in the network was generated randomly, but in real world it may obtain from the network management system. The cell with high probability (and with high cell load) will be chosen to be the starting cell for UE_v . The first column in the trace matrix represents the starting cell for all UEs.

According to the steady state vector obtained from markov model the cell residence time for each user is Independent and Identical Distributed (IID) random variable. The cell residence time is the time the UE spends in the cell before moving to one of the neighbor cells of current cell (handover process). In the algorithm the Residence Time (RT) for cell i will be calculated as follows:

$$RT = \pi_i * T \text{ min} \quad (5)$$

Design Optimization of Tracking Area List for Reducing Total Signaling Overhead in LTE Systems

Where

π_i represents the portion of time T that the UE spent in cell i.

- In the trace matrix the UE makes handover to the neighbor cell with high handover probability; this probability is calculated from the following formula:

$$P_{ij} = \frac{h_{ij}}{\sum_{p \in A_i} h_{ip}} \quad (6)$$

Where

P_{ij} is the probability that UE will make handover from cell i to cell j,

A_i is a set contains indexes of neighbor cells of cell i.

h_{ij} is the number of users making handover from cell i to cell j,

h_{ip} is the total number of users making handover from cell i to neighbor cell p.

We assumed that at any given time slot in the trace matrix and if the UE decided to make a handover process, it will move to the neighbor cell with high handover probability. Handover values (number of users making handover) which are used to calculate the handover probability discussed above are generated randomly but in real world it can be obtained from network management system.

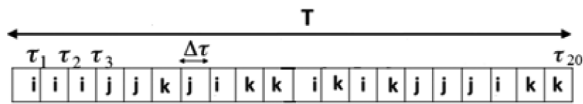

Fig.4. An example of one raw in the trace matrix

In the example shown in Fig.4 the time interval T is divided into 20 time slots. The cell load u_i is defined as the total number of UEs in cell i scaled by the time proportions that the UEs spend in cell i. Therefore, the load of each cell in the network is aggregated by the scaled values of UEs staying in the cell using all the elements of the trace matrix. The aggregated handover value is the number of moves from one cell to another [1].

Consider the example above, the aggregated cell load and handover for UE_v are:

$$u_i = 0.35, u_j = 0.3, u_k = 0.35, \text{ and } h_{ij} = 1, h_{jk} = 1, h_{kj} = 2, h_{ji} = 2, h_{ki} = 2, h_{ik} = 3. \text{ Where } \frac{\Delta\tau}{T} = 0.05.$$

D. CALCULATION OF OVERALL SIGNALING OVERHEAD

To calculate overall signaling overhead the cell load and handover data between each neighbor cells are required. These data are calculated directly from the trace matrix discussed in Section C, Here the load of each cell was aggregated by the scaled values of UE staying in the cell using all elements in the trace matrix. In the proposed algorithm we assumed that the TA consists only of one cell. For the traditional TA scheme handover data was aggregated from the trace matrix as follows, if a UE makes handover from cell i to cell j this means that h_{ij} will increase by one, So the h_{ij} value also calculated using all elements in the trace matrix.

Equation (7) below is used to calculate the overall signaling overhead for the TA scheme.

$$C_{SO}(t) = \sum_{i \in N} \sum_{j \in N: j \neq i} (h_{ij} c^u (1 - S_{ij}(t)) + \alpha u_i c^p S_{ij}(t)) \quad (7)$$

Where

h_{ij} is the number of users performed handover from cell i to cell j (if i and j are not in the same TA).

c^u is the update cost caused by one UE,

c^p is the amount of overhead of one paging.

α is the probability that a UE has to be paged (also called call intensity factor).

u_i is the total number of UEs in cell i scaled by time proportion each UE spent in cell i. It can be obtained by collecting UE statistics over a given time (using the trace matrix).

In (7) the first term represents the overhead caused by the location update process for users moving from cell i to cell j (if the two cells are not in the same TA), and the second term represents the overhead caused by the paging process (if the two cells are in the same TA).

To calculate the overall signaling overhead a TA design is required, the design of the TA is represented by the S(t) matrix, its N×N binary matrix where N is the number of cells in the networks. The value of element $S_{ij}(t)$ is determined as follows:

$$s_{ij}(t) = \begin{cases} 1 & \text{if } t_i = t_j \\ 0 & \text{otherwise} \end{cases}$$

Where

t_i is the TA of cell i, and t_j is the TA of cell j.

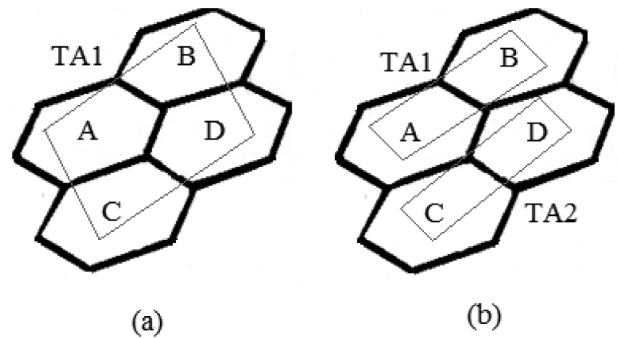

Fig.5. An example of the TA scheme

If all cells are included in one TA Fig(5.a) then the S(t) matrix is

$$S(t) = \begin{pmatrix} 1 & 1 & 1 & 1 \\ 1 & 1 & 1 & 1 \\ 1 & 1 & 1 & 1 \\ 1 & 1 & 1 & 1 \end{pmatrix}$$

In this case the overall signaling overhead calculated is:

$$C_{SO1}(t) = 3\alpha c^p (u_A + u_B + u_C + u_D) \quad (8)$$

Where

u_A, u_B, u_C and u_D are the cell load of cells A, B, C, and D respectively.

The signaling overhead calculated in (8) is introduced by paging process because all cells are in the same TA and there is no location update cost.

If cell A and B are in one TA and cell C and D are in another TA as shown in Fig (5.b), then the $s(t)$ matrix is

$$S(t) = \begin{pmatrix} 1 & 1 & 0 & 0 \\ 1 & 1 & 0 & 0 \\ 0 & 0 & 1 & 1 \\ 0 & 0 & 1 & 1 \end{pmatrix}$$

And the overall signaling overhead calculated is:

$$C_{so2}(t) = c^u(h_{AC} + h_{AD} + h_{BC} + h_{BD} + h_{CA} + h_{CB} + h_{DA} + h_{DB}) + \alpha c^p(u_A + u_B + u_C + u_D) \quad (9)$$

In the TAL scheme, different UEs in one cell are holding different TALs according to the original cell they are registered in. If we define $s_{ij}(t)$ as the number of UEs in cell i , who have j in their list divided by the whole number of UEs in cell i , then $S(t)$ cannot remain as a binary matrix, but it will rather contain some fractional values between 0 and 1. The authors in [4] gave an example and showed that if cell A perceps that cell B is in another TA but cell B assumes that they are in the same TA, this flexibility could lead to a lower overhead. As discussed in [4] $s_{ij}(t)$ is given by the following formula.

$$S_{ij}(t) = \frac{u_i l_{ij} + \gamma \sum_{n \in Q_i} h_{ni} l_{nj}}{u_i + \gamma \sum_{n \in Q_i} h_{ni}} \quad (10)$$

Where:

$S_{ij}(t)$ presents the percentage of users in cell i having j in their TAL.

Q_i is the set of neighbor cells of cell i having i in their TAL, l_{ij} is a parameter and it's equal to 1 if i and j are in the same TAL and 0 otherwise.

γ is the probability of UEs entering cell i from a neighbor cell and have i in their TAL, in this case UEs will enter cell i without performing update process.

Equation (7) is also valid in the calculation of the overall signaling overhead for TAL scheme. For both traditional TA and TAL schemes, the calculation of overall signaling overhead requires:

- A well defined $S(t)$ matrix which represents the design of TAs or TALs in the network,
- The cell load u_i for each cell in the network, and it can be obtained from the trace matrix. Cell load is aggregated by the scaled values of UEs staying in the cell using all the elements of the trace matrix as discussed in the example shown in fig3.
- Handover statistics which are the number of users performed handover from cell i to cell j . Also it can be obtained from the trace matrix discussed in Section C.

E. ALGORITHM BODY

The proposed algorithm returns the overall signaling overhead cost for an optimum TAL design. First the value of parameter B should be determined (It's the budget constrain parameter), this value is a percentage of the total cells load.

An important variable also defined which is bl variable. Initial value of this variable is 0, and it's used to check whether the movement of cell j from its current TAL to another TAL is within the budget constrain or not. When cell j changes its current and initial TAL bl value will increase by u_j (cell load value). And if cell i moves back from its current TAL to its initial TAL bl value will decrease by u_j .

Here the condition is that the value of bl after cell movement should be always less than the value of parameter B. In the design of this algorithm TALs overlapping is considered which means that one cell may be included in two or more TAL. Algorithm code can be summarized as follows:

- Define initial TAL design by the definition of $S(t)$ matrix and determine the starting TAL for each cell in the network by using (4).
- Calculate the overall signaling overhead for the initial TAL design (Variable CS).
- Calculate B according to (11) below:

$$B = q \times U \quad (11)$$

Where $U = \sum_{i=1}^N u_i$ and $q \leq 1$

- Select a random cell i , and then for all cell j in the network check whether j is in the same TAL of i or not. If j and i are in the same TAL remove j from TAL of i .
- Update S_{ij} element defined by equation () in the $S(t)$ matrix. Update ADL which is a set containing all adjacent cells to TAL_i and are not included in the list.
- For all cell p which is a cell included in TAL_i and TAL_j update $s_{jp}(t)$ and $s_{pj}(t)$ elements. Calculate the overall signaling overhead cost for the new TAL design.
- If the new cost is less than the initial cost update bl value. And replace the initial TAL design with the new one, otherwise keep current TAL design.
- Repeat the steps mentioned above till we get an optimum TAL design which gives minimum overall signaling overhead cost. Or bl value reached B value.

Design Optimization of TAL Algorithm:

- 1- Definition:
- 2- ST is the initial $S(t)$ matrix.
- 3- STT is the current $S(t)$ matrix, which describes the current TAL design.
- 4- ADL is a set contains the indexes of the neighbor cells of TAL_i .
- 5- CS is the initial overall signaling overhead calculated based on ST matrix.

Design Optimization of Tracking Area List for Reducing Total Signaling Overhead in LTE Systems

```

6- CSO is the minimum overall signaling overhead
   returned by the algorithm.
-----
7- Construct the trace matrix.
8- Determine the starting TAL for each cell in the
   network to create the first column in the matrix.
9- Create the ST matrix according to equation ( ).
10- STT=ST; , CS=T_cost(ST);
11- calculate B.
12- bl=0; , l=1;
13- while bl<B
14- select a random cell i
15- for j=1:61
16- If j is in same TAL with i , remove j from the
   TAL of i
17- update sij element in the STT matrix,
18- For all p which is a cell included in TALi and TALj
   update sjp and spj elements. and ADL set
19- end
20- CSO=T_cost(STT);
21- if CSO<CS
22- ST=STT; CS=CSO; ADL=TN;
23- bl=bl+U(j);
24- else
25- STT=ST; TN=ADL;
26- end
27- If j is not included in the list of I, added j to the
   list and then update sij element in the STT matrix.
28- For all p which is a cell included in TALi and
   TALj update sjp and spj . and ADL set
29- end
30- CSO=T_cost(STT);
31- if CSO<CS
32- ST=STT; CS=CSO; , ADL=TN;
33- bl=bl+U(j);
34- else
35- STT=ST; , TN=ADL;
36- end
37- end
38- end
    
```

IV. NUMERICAL RESULTS

Given the UE traces matrix and a TAL design the exact S(t) matrix elements can be calculated and the aggregated cell load and handover data can be obtained as discussed in Section C. The state transition probability matrix shown in Fig.6 below is used for handover decision in the trace matrix. In this matrix probability values are calculated using (6).

0.30	0.12	0.05	0.02	0.30	0.28	0.04
0.10	0.36	0.12	0.10	0.02	0.05	0.03
0.25	0.13	0.36	0.18	0.12	0.20	0.10
0.02	0.22	0.22	0.12	0.16	0.02	0.20
0.11	0.02	0.10	0.18	0.21	0.12	0.03
0.04	0.10	0.02	0.30	0.09	0.03	0.40
0.18	0.05	0.13	0.10	0.10	0.30	0.20

Fig.5: State Transition Probability Matrix

As mentioned in Section B cell residence times are IID random variables. Fig.6 below shows the Steady State probability vector, which is used in the algorithm to calculate cell residence time.

$\frac{1}{7}$	$\frac{1}{7}$	$\frac{1}{7}$	$\frac{1}{7}$	$\frac{1}{7}$	$\frac{1}{7}$	$\frac{1}{7}$
---------------	---------------	---------------	---------------	---------------	---------------	---------------

Fig.6: Steady State Probability Vector

The tables below show the overall signaling overhead calculated from both standard TA optimum design algorithm implemented using the same methodology as in [1] and the proposed TAL design optimization algorithm. In each table the results calculated for ten different scenarios, each scenario represents a cell load and handover data set. Each table represents the results for a given value for both B and ∞ parameters. B value is a percentage of total number of UEs (U) in the network. We assumed that the number of UEs in all UE trace scenarios is 6000. UEs were traced for one hour period, this period was divided into 60 equal intervals and every time interval is equal to one minute. We assumed that $C_u=1$, $C_p=1$ (common in the literature), Also we assumed that the average value of γ is 0.05.

Both standard TA optimum design algorithm and TAL optimum design algorithm were implemented using MATLAB, the algorithms run on a processor of type Intel core™ i3 with clock speed of 2.35 GHz. In the design of the network we assumed that there are 23 TAs. And each TA contains only one cell (to simplify calculations). Each TAL may contain two or three TAs (depends on the suggested initial TAL design). Tables below show the overall signaling overhead calculations for different scenarios and data sets. For each scenario the location update cost and paging cost were calculated. The dimension of the trace matrix in all scenarios is 6000×60. Numerical results presented in tables below show the location update, paging cost and total cost for ten different scenarios.

TABLE I
NUMERICAL RESULTS FOR B=15%U & $\infty=0.01$.

Scen-ario	Optimum STA scheme			Optimum TAL scheme		
	TAU	Paging	Overall	TAU	Paging	Overall
1	25011	581	25592	19341	352	19693
2	25623	575	26198	19834	370	20204
3	25412	582	25994	20021	355	20376
4	25838	602	26440	20051	302	20353
5	24321	543	24864	19863	331	20194
6	25452	562	26014	19761	321	20082
7	24998	576	25574	20023	348	20371
8	25902	530	26432	20021	358	20379
9	25645	610	26255	19781	341	20122
10	24984	552	25536	20023	332	20355

TABLE II
NUMERICAL RESULTS FOR B=50%U & $\alpha=0.02$

Scen-ario	Optimum STA scheme			Optimum TAL scheme		
	TAU	Paging	Overall	TAU	Paging	Overall
1	27168	1018	28186	20068	996	21064
2	27532	989	28521	20112	872	20984
3	26972	1105	28077	19664	1012	20676
4	26884	1231	28115	18841	1002	19843
5	27153	1222	28375	18542	1132	19674
6	26341	996	27337	18731	865	19596
7	27132	1003	28135	18643	1423	20066
8	27634	979	28613	19997	1322	21319
9	27166	1017	28183	19821	1231	21052
10	26878	1033	27911	18732	1399	20131

TABLE III
NUMERICAL RESULTS FOR B=100%U & $\alpha=0.05$

Scen-ario	Optimum STA scheme			Optimum TAL scheme		
	TAU	Paging	Overall	TAU	Paging	Overall
1	27511	931	28442	4226	1798	6024
2	27504	971	28475	4321	1781	6102
3	27555	967	28522	4223	1756	5979
4	26998	943	27941	4651	1795	6446
5	27541	930	28471	4659	1752	6411
6	27510	895	28405	4213	1734	5947
7	27453	984	28437	4551	1722	6273
8	27423	932	28355	4223	1793	6016
9	26978	951	27929	4512	1721	6233
10	27132	940	28072	4224	1790	6014

From tables shown above we may conclude the following:

- The total signaling overhead calculated and recorded in table I shows that the optimum design of TAL is 19% to 23% better than standard TA design. The paging cost is less than the location update cost and it depends on the value of parameter α . Results were calculated for B=15% and $\alpha=0.01$ which means that 1% of the UEs will be paged in every cell.
- The overall signaling overhead calculated and shown in table II shows that the optimum design of TAL is 25% to 31% better than standard TA design. The paging cost is less than the location update cost and greater than the paging cost shown in table I this is because here $\alpha = 0.02$.
- The overall signaling overhead shown in table III shows that the optimum design of TAL is 77% to 79% better than standard TA design. And this because B is 100%U which means that there is no restriction in the design of the TALs and we can freely move cells from TAL to another until we reach the optimum design. The table gives best results when compared to other tables, but with no budget constrain the service interruption when changing the TAL of a cell will affect the performance of the network in a great manner. In the proposed algorithm average value of γ

was chosen to be 0.05, and it's required to give a good estimation of γ because it influences the TAL design and the resulting signaling overhead.

V. CONCLUSION

In this paper we proposed design optimization of TAL for reducing overall signaling overhead algorithm. The proposed algorithm returns the minimum overall signaling overhead calculated based on the optimum TAL design. And markov model is used as the UE mobility model. The numerical results obtained from the proposed algorithm show that the design of TAL scheme with TAL overlapping reduces the overall signaling overhead compared to the standard TA scheme. And with large value of B we got better performance of the TAL scheme but we should take into account the service interruption caused by cell movement from TAL to another to keep the acceptable performance of the system.

For future work we suggest to extend the idea of this paper to include a comparison between different mobility models to examine their effect on the reduction of overall signaling overhead when applied to the same scenario.

REFERENCES

[1] Modarres Razavi, Sara. "Tracking Area Planning in Cellular Networks: Optimization and Performance Evaluation." PhD diss., Linköping, 2011.

[2] Razavi, S. Modarres, Di Yuan, Fredrik Gunnarsson, and Johan Moe. "Dynamic tracking area list configuration and performance evaluation in LTE." In GLOBECOM Workshops (GC Wkshps), 2010 IEEE, pp. 49-53. IEEE, 2010.

[3] Szalka, Tamas, Sandor Szabo, and PÉTER FÜLÖP. "Markov model based location prediction in wireless cellular networks." Infocommunications Journal (2009): 40.

[4] Razavi, Sara Modarres, Di Yuan, Fredrik Gunnarsson, and Johan Moe. "Exploiting tracking area list for improving signalling overhead in LTE." In Vehicular Technology Conference (VTC 2010-Spring), 2010 IEEE 71st, pp. 1-5. IEEE, 2010.

[5] Wu, Chien-Hsing, Huang-Pao Lin, and Leu-Shing Lan. "A new analytic framework for dynamic mobility management of PCS networks." Mobile Computing, IEEE Transactions on 1, no. 3 (2002): 208-220.

[6] Liou, R., Y. Lin, and S. Tsai. "An investigation on LTE mobility management." IEEE Transaction on mobile computing(2011), vol 12, no. 1,pp 166-176,2011.

[7] Lin, Yi-Bing. "Reducing location update cost in a PCS network." IEEE/ACM Transactions on Networking (TON),vol 5, no. 1 ,pp 25-33, 1997.

[8] 3GPP. 3rd Generation Partnership Project; Technical Specification Group Services and System Aspects; General Packet Radio Service (GPRS) enhancements for Evolved Universal Terrestrial Radio Access Network (E-UTRAN) access. Technical Specification 3G TS 23.401 version 10.0.0 (2010-06), 2010.

[9] 3GPP. 3rd Generation Partnership Project; Technical Specification Group Radio Access Network; Evolved Universal Terrestrial Radio Access (E-UTRA) and Evolved Universal Terrestrial Radio Access Network (E-UTRAN); Overall description; Stage 2. Technical Specification 3G TS 36.300 version 10.1.0 (2010-09), 2010.

Design Optimization of Tracking Area List for Reducing Total Signaling Overhead in LTE Systems

[10] Razavi, Sara Modarres, and Di Yuan. "Performance improvement of LTE tracking area design: a re-optimization approach." In Proceedings of the 6th ACM international symposium on Mobility management and wireless access, pp. 77-84. ACM, 2008.

[11] Jardosh, Amit, Elizabeth M. Belding-Royer, Kevin C. Almeroth, and Subhash Suri. "Towards realistic mobility models for mobile ad hoc networks." In Proceedings of the 9th annual international conference on Mobile computing and networking, pp. 217-229. ACM, 2003.

[12] Zonoozi, Mahmood M., and Prem Dassanayake. "User mobility modeling and characterization of mobility patterns." Selected Areas in Communications, IEEE Journal on 15, no. 7 (1997): 1239-1252.

[13] Liang, Ben, and Zygmunt J. Haas. "Predictive distance-based mobility management for PCS networks." In INFOCOM'99. Eighteenth Annual Joint Conference of the IEEE Computer and Communications Societies. Proceedings. IEEE, vol. 3, pp. 1377-1384. IEEE, 1999.



Lamia Osman Widaa received her BSc in Electrical Engineering from University of Khartoum, Sudan in 1996. She did her MSC in Telecommunication & Information Systems from department of Electrical & Electronic Engineering, faculty of Engineering, university of Khartoum (UofK), Sudan in 2002.

Currently she is doing her PhD research in telecommunication & information systems at the faculty of Electrical Engineering, University of Khartoum (UofK), Sudan, under the supervision of Prof Dr.Sami Mohamed Sharif. Her current research interests are in the area of optimum design of Tracking Area Lists for LTE systems.



Sami Mohamed Sharif received his BSc in Electrical Engineering from Faculty of Engineering, University of Khartoum (UofK), Sudan in 1980. PhD degree in electrical engineering from UofK, Faculty of Electrical Engineering in 1988, and PhD title "Effect of Dust storms on Microwave signal propagation". Currently, he is a Professor with the Faculty of Electrical Engineering, (UofK), and the secretary of academic affairs in UofK.

His current research interests are in Networking, Switching and teletraffic engineering, Radio wave propagation and Electromagnetic, Information Technology and Communications, Electronic Systems, ICT Economics and regulation.